

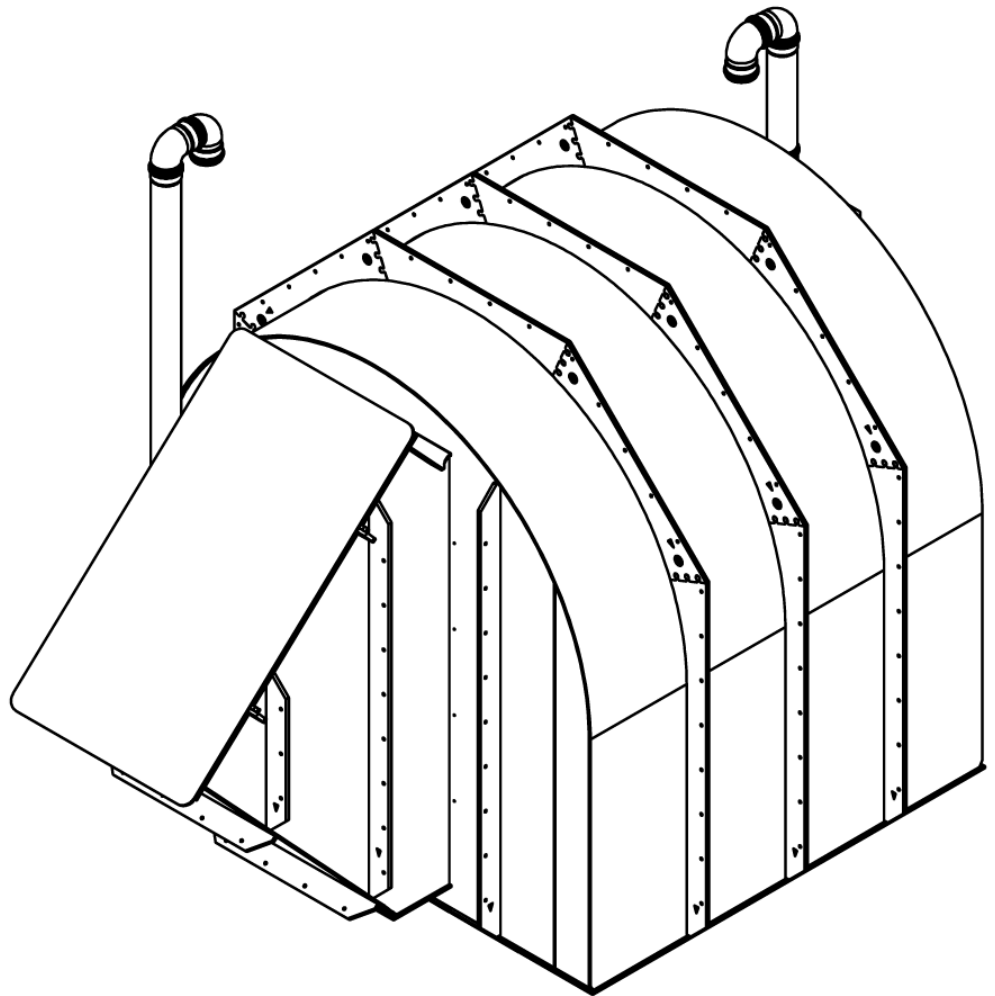

Kolomäki

INSTALLATION MANUAL AND WARRANTY CERTIFICATE OF SHELTERS AND CELLARS QUICK FOR CONCRETING



Material: Certified food grade polypropylene
Sizes: 4,4m², 6,6m², 8,8m²

Date of issue: 01_2023

Cellars and shelters

designed for underground installation.

Before you begin with the product installation, please read this manual carefully and follow it! Failure to adhere to the installation instructions will void your warranty.

Table of Contents.

1. Basic Information.
2. Table of Dimensions, Weight, and Equipment.
3. Manufacturer's Responsibility.
4. Product Selection and Placement Conditions.
 - 4.1. Basic Requirements.
 - 4.2. Excavation for Construction.
 - 4.3. Placement in Relation to Buildings.
 - 4.4. Placement on Slopes.
 - 4.5. Non-Standard Installation Situations.
5. Transportation.
6. Product Installation.
7. Manufacturer.
8. Warranty Certificate.

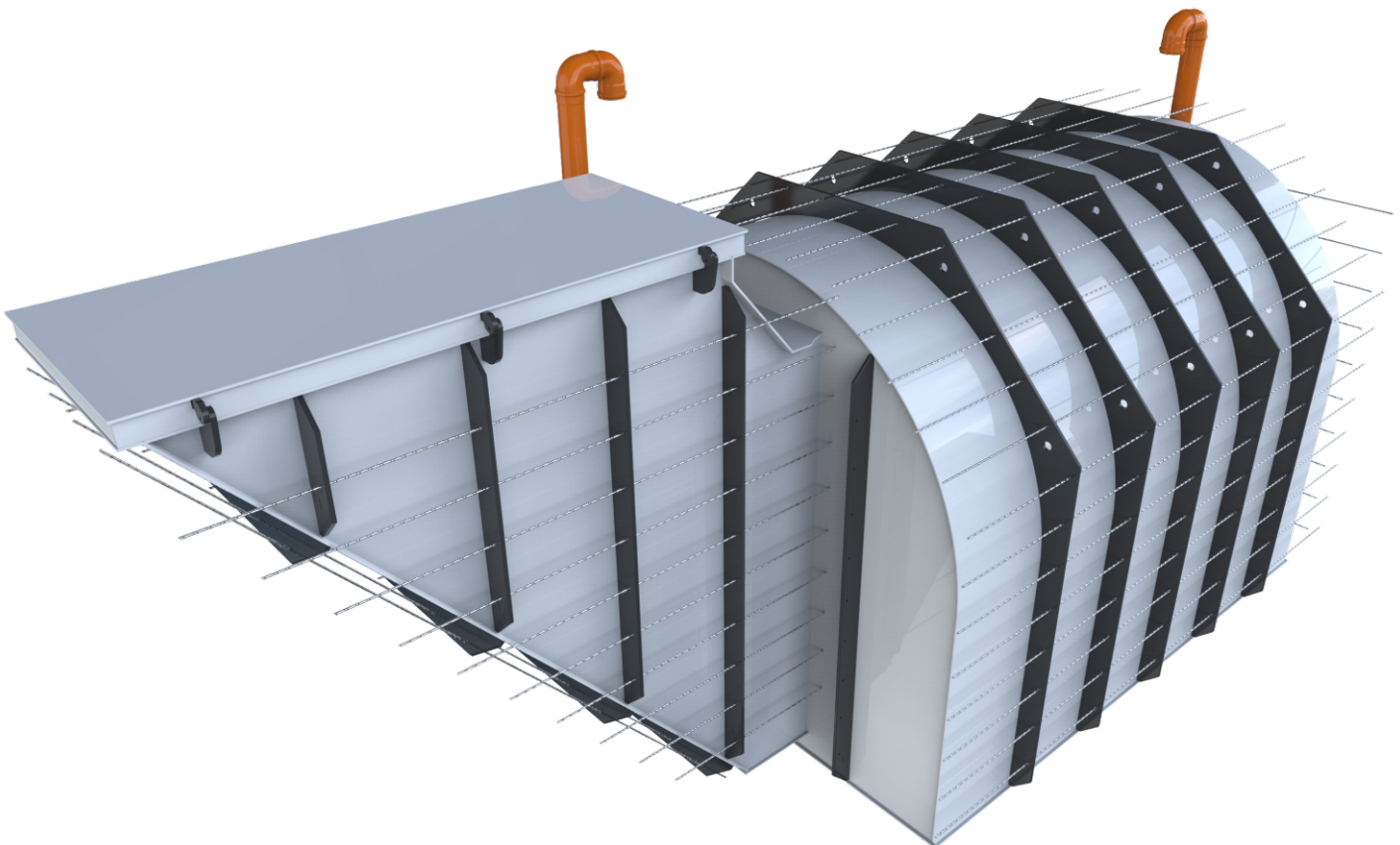

1. Basic information.

Products Kolomaki Quick

Cellars and shelters are manufactured in four basic designs:

Quick 1 – sloping entrance above ground.

Quick 2 – horizontal entrance at ground level.

Quick 3 – vertical entrance above ground.

Quick 4 – Direct vertical entrance.

Products constructed in this manner have been developed and manufactured in the Czech Republic for many years. The gradual evolution of the production of various generations of plastic products has led to their current form, making them highly popular not only for their strength, durability, and low weight but also due to their performance-to-price ratio. The material is smooth and glossy, which prevents dirt from adhering to it.

2. Tables of dimensions, weight, and equipment.

Quick 1	2000	3000	4000
Area (m ²)	4.4	6.6	8.8
Dimensions (LxHxW, mm)	3600*2320*2400	4600*2320*2400	5600*2320*2400
Weight(kg)	480	560	640
Entrance door	Yes	Yes	Yes
Stairs	Yes	Yes	Yes
Entrance type	Sloping	Sloping	Sloping
Concrete	Yes	Yes	Yes
Plastic ribs	Yes	Yes	Yes

2. Tables of dimensions, weight, and equipment.

Quick 2	2000	3000	4000
Area (m2)	4.4	6.6	8.8
Dimensions (LxHxW, mm)	4570*2500*2400	5570*2500*2400	6570*2500*2400
Weight(kg)	520	600	680
Entrance door	Yes	Yes	Yes
Stairs	Yes	Yes	Yes
Entrance type	Horizontal	Horizontal	Horizontal
Concrete	Yes	Yes	Yes
Plastic ribs	Yes	Yes	Yes

Quick 3	2000	3000	4000
Area (m2)	4.4	6.6	8.8
Dimensions (LxHxW, mm)	4770*4415*2400	5770*4415*2400	6770*4415*2400
Weight(kg)	570	650	730
Entrance door	Yes	Yes	Yes
Stairs	Yes	Yes	Yes
Entrance type	Vertical	Vertical	Vertical
Concrete	Yes	Yes	Yes
Plastic ribs	Yes	Yes	Yes

2. Tables of dimensions, weight, and equipment.

Quick 4	2000	3000	4000
Area (m2)	4.4	6.6	8.8
Dimensions (LxHxW, mm)	2390*2320*2400	3390*2320*2400	4390*2320*2400
Weight(kg)	460	540	620
Entrance door	Yes	Yes	Yes
Stairs	Yes	Yes	Yes
Entrance type	Vertical	Vertical	Vertical
Concrete	Yes	Yes	Yes
Plastic ribs	Yes	Yes	Yes

3. Manufacturer's Responsibility.

THE MANUFACTURER IS RESPONSIBLE FOR:

1. Overall product quality, compliance with all standards.
2. Execution, weld quality, production process control.
3. Inspections of all incoming materials from suppliers.
4. Providing production number and label for potential control.
5. Production is certified by TZUS Prague.

IS NOT RESPONSIBLE FOR DAMAGES CAUSED BY:

1. Incorrect installation.
2. Inappropriate placement selection.
3. Using the product for a purpose other than its intended use.
4. Inappropriate transportation methods.

IT IS IMPOSSIBLE FOR THIS MANUAL TO COVER ALL SITUATIONS THAT MAY ARISE DURING INSTALLATION. PLEASE CAREFULLY CONSIDER ANYTHING THAT COULD POTENTIALLY DAMAGE THE PRODUCT IN ANY WAY!

4. Selection and conditions for the placement of the cellar/shelter.

4.1. Basic Conditions.

To select the product correctly, it is necessary to determine the type and location of the installation. Different types of products are intended for different geological conditions. (A hydrogeological assessment for the specific soil is usually part of the building permit.)

4.2. Excavation for Construction.

The construction excavation must be dug on a sufficiently large area to ensure the width of the working space is maintained. The dimensions of the construction excavation are determined by the type of product - see the table for each type.

4.3. Placement in Relation to Buildings.

The cellar/shelter must not be obstructed! Load caused by any building could lead to deformation. The cellar/shelter must be at least 1 meter away from the building.

4.4. Placement on Slopes.

In the case of installation on a slope, terrain assessment is necessary to prevent soil sliding or other complications. Static calculations and assessment of the suitability of the subsoil or slope's stability must be carried out by a structural engineer.

4.5. Non-Standard Installation Situations.

All non-standard installations must be assessed by a structural engineer to eliminate possible danger. Based on the project, an expert must provide an additional structural assessment.

5. Delivery.

Transportation, loading, and unloading of the product must be carried out with caution. Securing during transportation must be done carefully, and damage during any stage is not allowed. It is recommended to load and unload using a crane, excavator, or forklift.

6. Product installation.

The product for concreting is suitable for locations with higher static loads. It is not suitable for areas with a high water table and unstable foundations.

Installation Procedure:

At the chosen location, we will excavate 20 cm wider on each side to create a workspace and space for concreting. We will pour a reinforced concrete slab with a steel mesh of at least 8x15 at a height of 15 cm into the bottom of the excavation. Allow the slab to cure.

The cellar/shelter is placed on a level, cured slab without sharp objects that could damage it! We recommend placing 1 cm of extruded polystyrene between the slab and the bottom of the product. If the cellar/shelter is buried less than 20 cm in soil or has interlocking pavement on it, place extruded polystyrene with a thickness of 50 mm above the cellar/shelter, extending 500 mm beyond the size of the cellar/shelter's diameter.

Before concreting, ventilation pipes must be connected. Due to the load during concreting, it is necessary to support the ceiling with props every meter and one distributing wooden beam in the center of the ceiling.

The cellar/shelter walls must be reinforced with three longitudinal wooden beams of 80/80 mm placed at the bottom and at heights of 500 and 1000 mm. These beams will be braced with horizontal wooden supports of 80/80 mm placed approximately a quarter of the length of the beams. Insert

reinforcing steel into the pre-prepared holes in the product's supports.

Bind the reinforcing steel vertically around the entire body of the product.

Connect them together with tying wire to create a network around the entire body of the product and the entrance. Only then can the cellar/shelter walls be concreted. In one day, do not concrete more than 100 cm in height.

The recommended thickness of the concrete around the cellar is 150 mm.

If the cellar/shelter is installed in areas with a high water table, drainage must be provided around the cellar/shelter to divert water away from it.

The product is not intended for areas with groundwater.

The removal of props and supports can be done only after the concrete has sufficiently set - at least 10 days.

6. Product installation.

Installation of a modular cellar/shelter:

In the case of a modular cellar/shelter, additional assembly is required. The pit must be large enough for all parts of the cellar/shelter. Concrete must cover the bottom of the entire pit.

Parts of the cellar/shelter must be connected with screws and an extrusion welding machine. This step is performed either before placing the cellar/shelter in the pit (if the overall size allows for manipulation) or in the pit after all parts are in place.

7. Installation of the cellar/shelter with bottom reinforcements.

The bottom part of the cellar/shelter floor is equipped with ribs with drilled holes at intervals of 200 mm, through which a 10 mm diameter reinforcement rod is threaded.

Additional 8 mm diameter reinforcements, positioned perpendicular (parallel to the ribs), are added at intervals of 300 mm.

The reinforcement rods are not included in the cellar/shelter delivery.

A 15 cm high layer of concrete is created on the bottom of the excavation. The prepared cellar/shelter is placed on the concrete in such a way that the reinforcements of the cellar/shelter floor with the reinforcement rods are embedded in the prepared concrete. It is necessary to use a slightly more fluid concrete (F6) and ensure proper compaction to ensure that the concrete flows into all areas from the bottom of the cellar/shelter.

The cellar/shelter must be in perfect alignment.

Allow the slab to cure properly (a technology break of 3 days).

Support placement before concreting

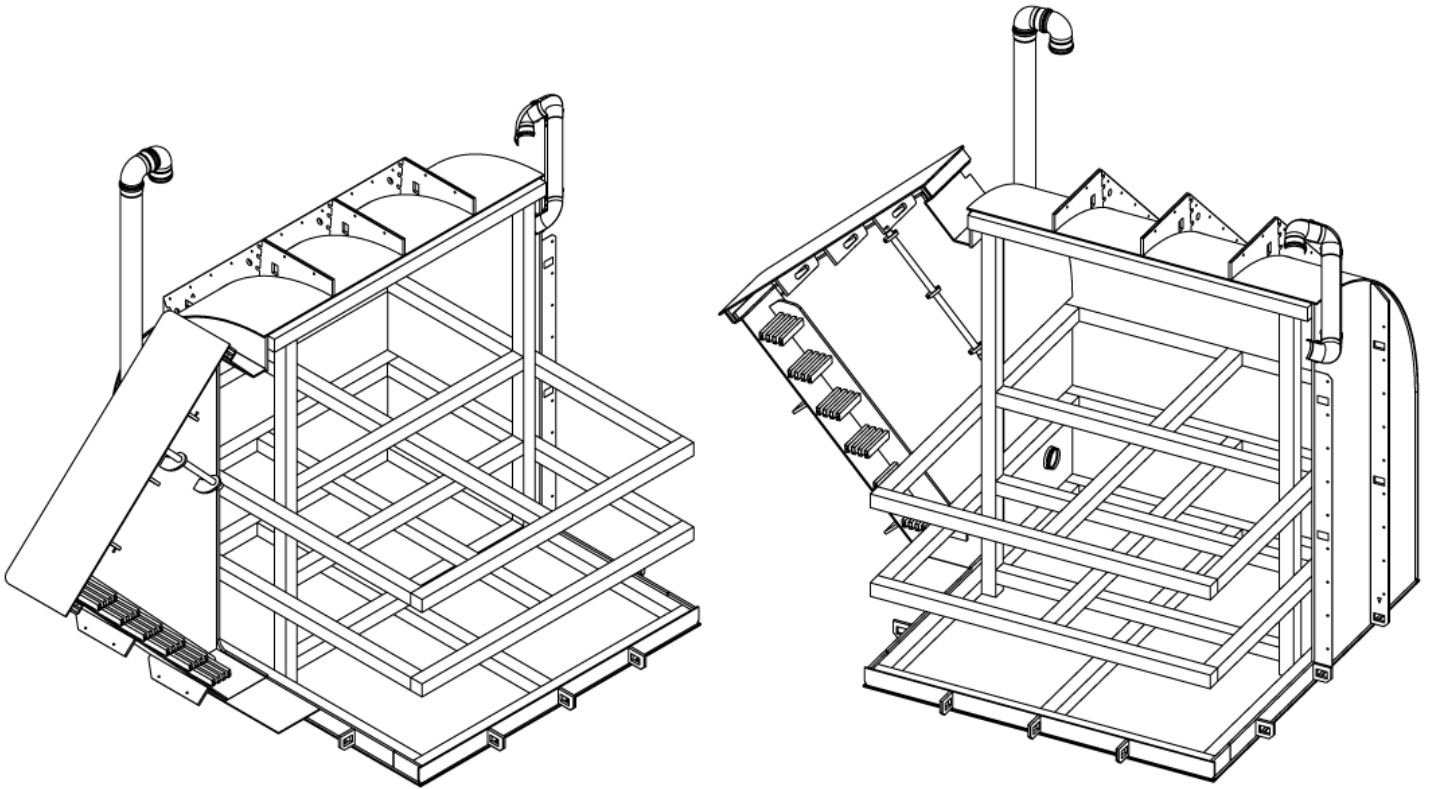

Instalation schematic

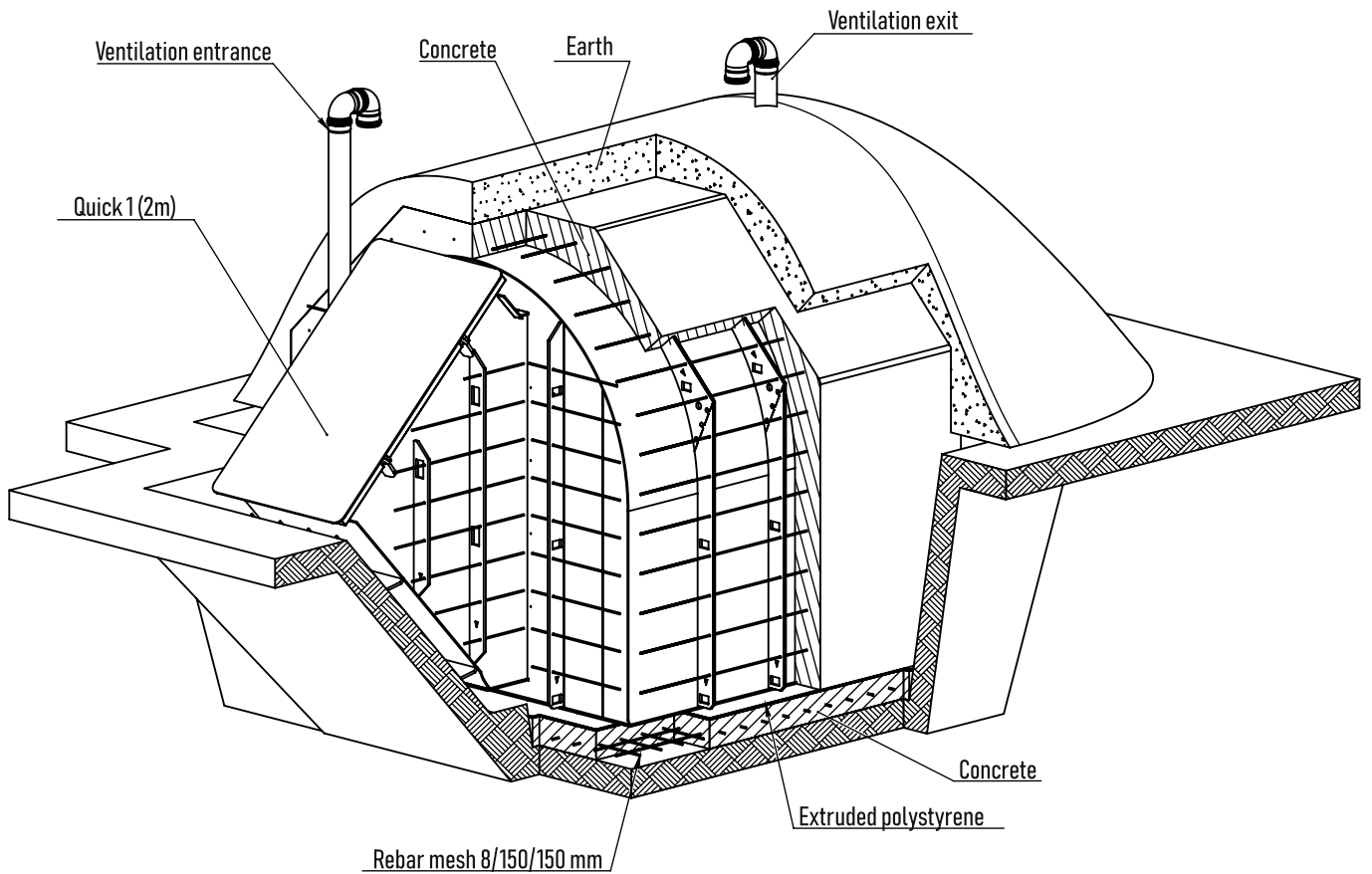

8. Manufacturer.

Kolomaki s.r.o.

ID 06142974

VAT ID Cz06142974

Address: Komenského 576, Zlonice 273 71, CZ

www.kolomaki.com

+420 777 899 323

9. Warranty certificate.

Product type _____

Product serial number _____

Manufacture date _____

Delivery date / instalation _____

Service (date, service provided, brief description of faults, and repairs)

recieved by:.....

delivered/completed by:.....

customer signature

stamp and signature